

REV.	ZONE	DESCRIPTION	DATE	APPROVED
A		INITIAL RELEASE	06/12/18	CMM

MOUNT PATTERN

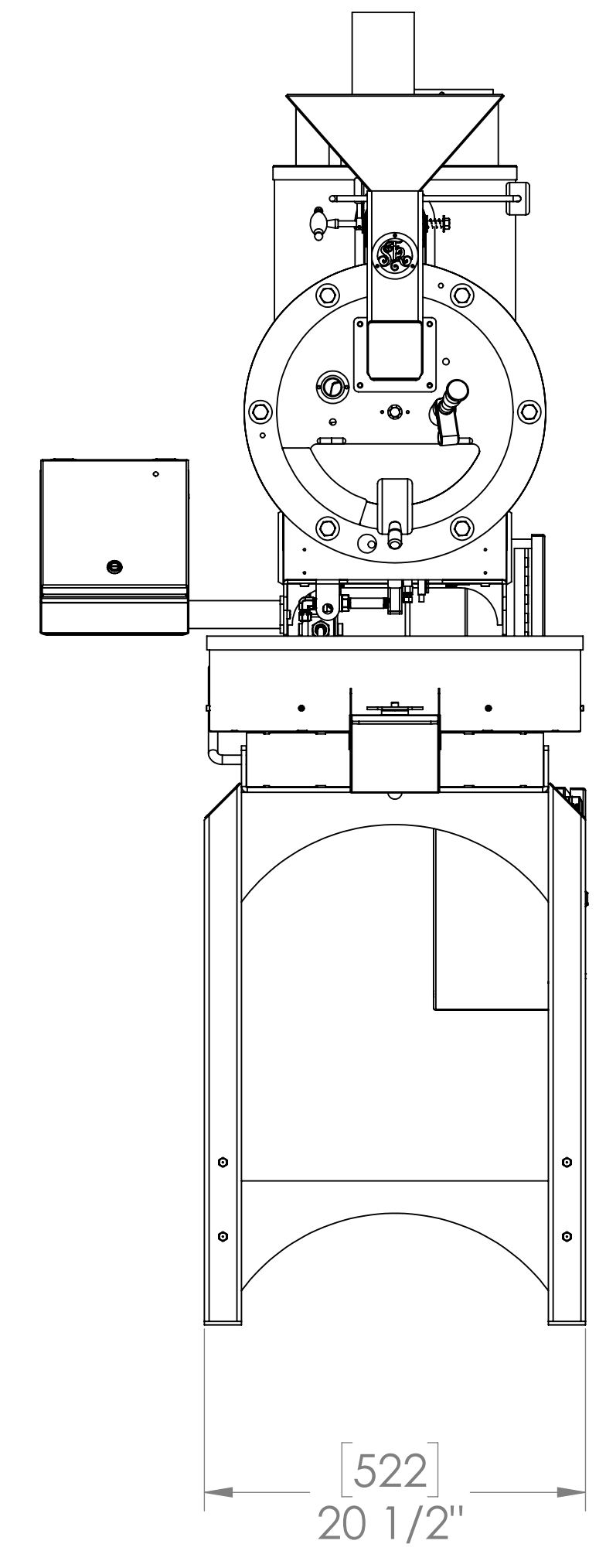
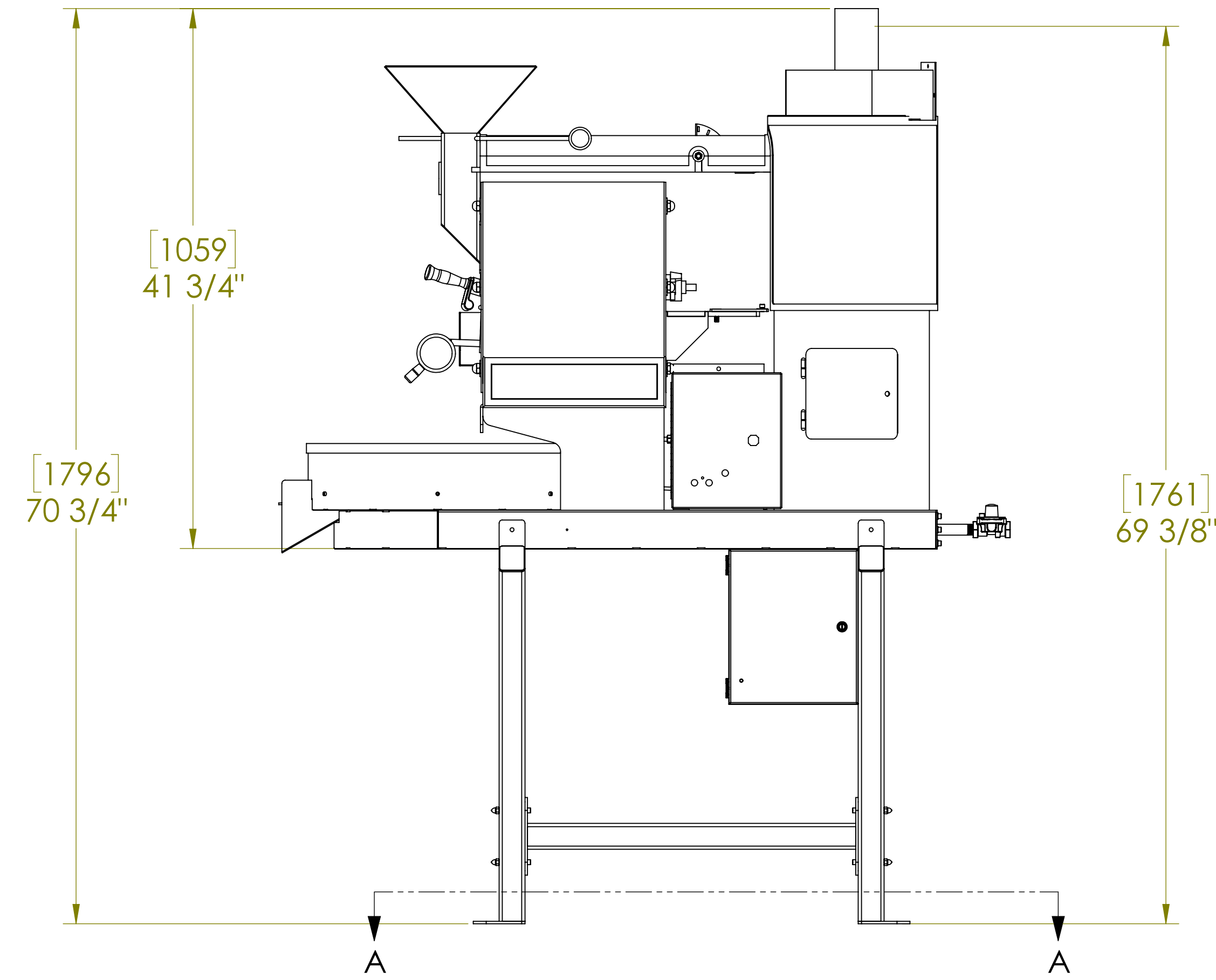
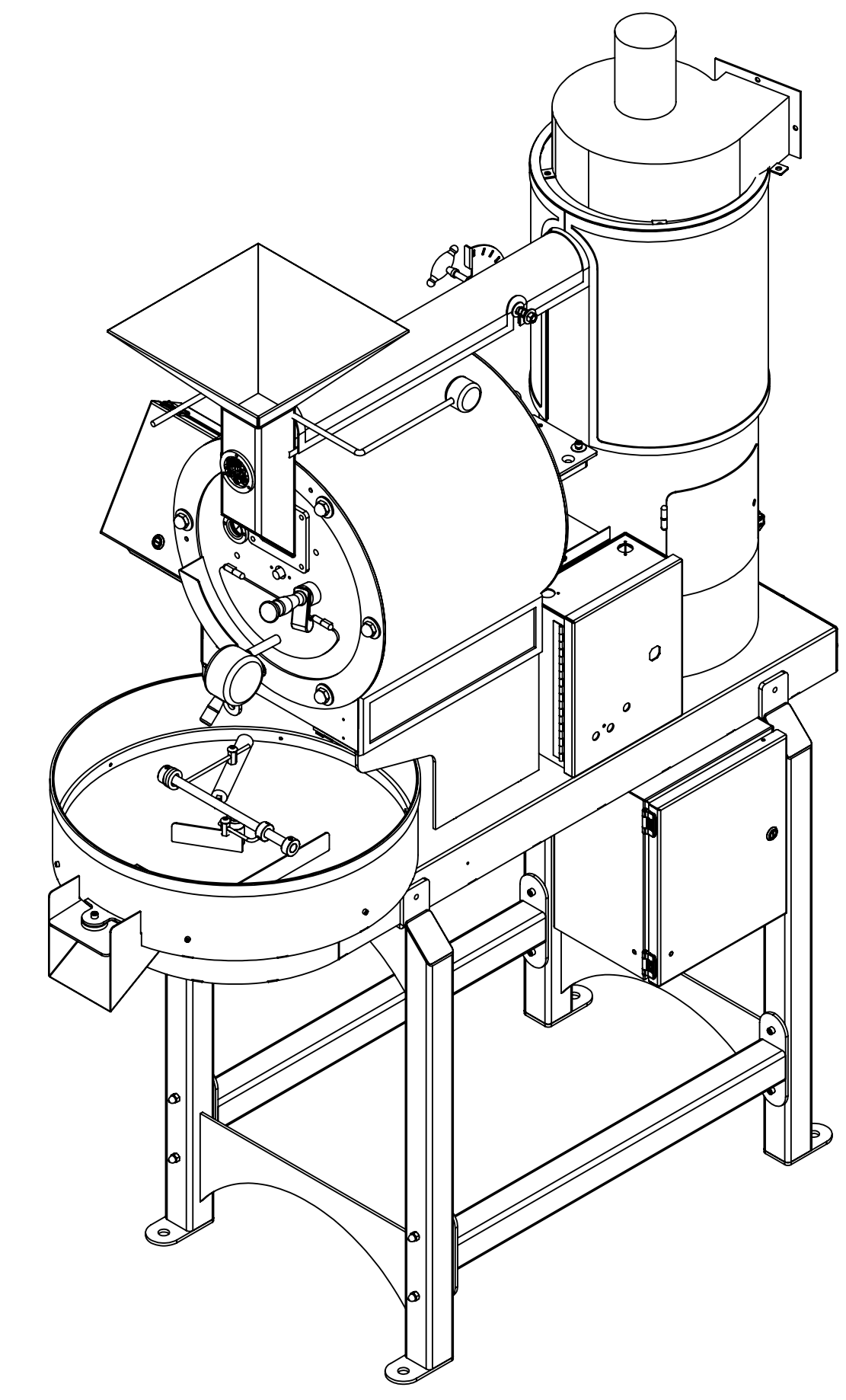
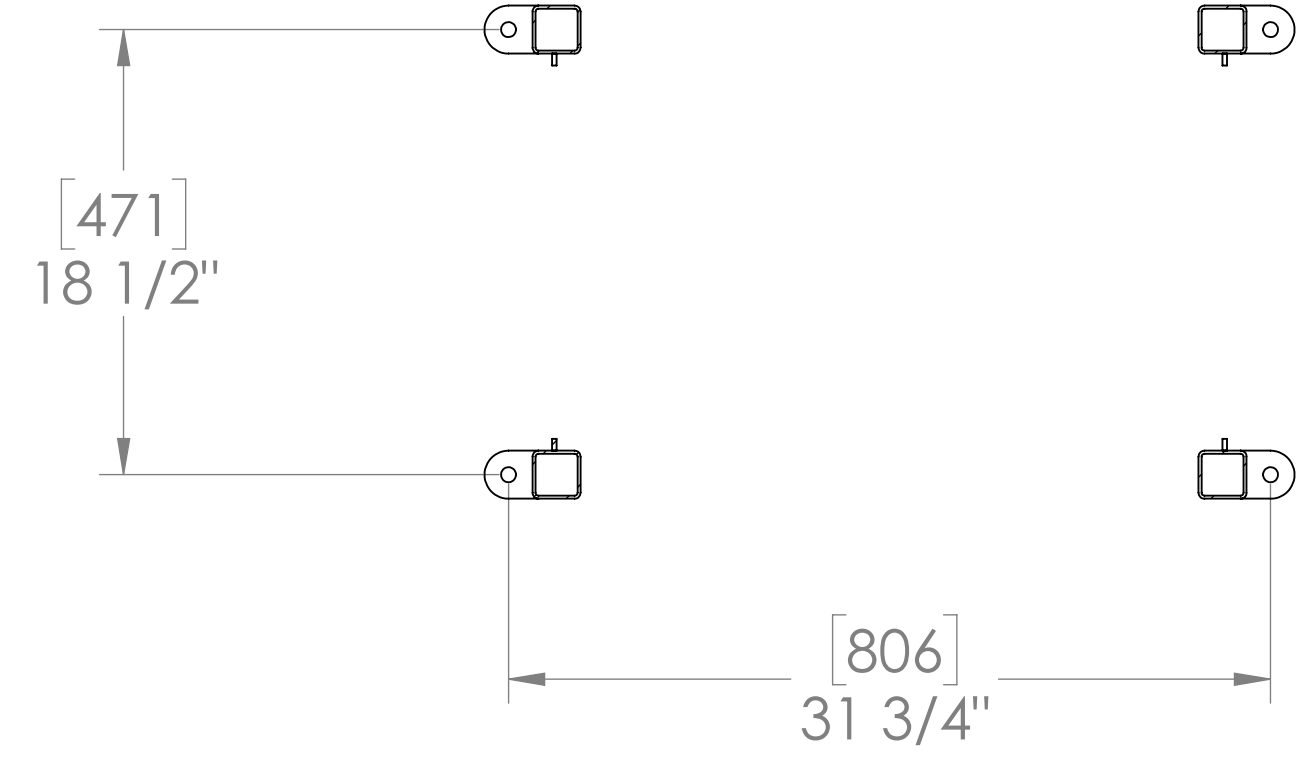
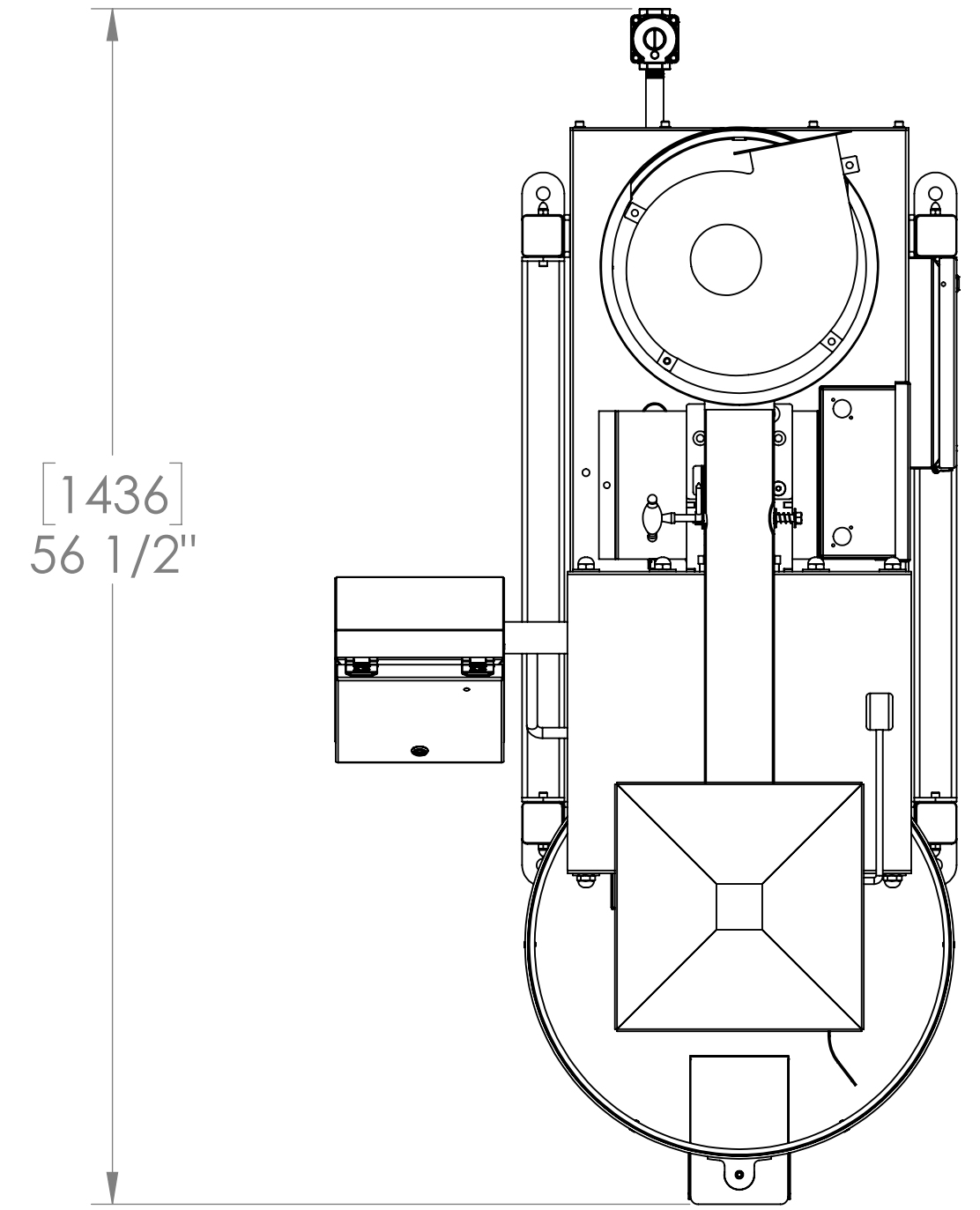

MAINTAIN 18" CLEARANCE FROM ALL COMBUSTIBLES AROUND ROASTER PERIMETER

DATA SHEET	
Weight	398 lbs / 161 kg
Dimensions w/o Stand (L x W x H)	50" x 22" x 42" / 127 cm x 56 cm x 107 cm
Dimension w/ Stand (L x W x H)	50" x 22" x 71" / 127 cm x 56 cm x 181 cm
Hot Air Exhaust	6" / 150 mm UL103 HT Positive Pressure Vent Pipe (225 CFM)
Voltage	220 V, 60 HZ
Amperage	9 A
Gas Line Req.	1/2" NPT
BTU	30,000 (7" WC Natural Gas / 11" WC Propane)
Approx. Hourly Capacity	18 lbs / 8.2 kg green, 15 lbs / 6.8 kg roasted
Certification	ETL Listed USA and Canada

PROPRIETARY INFORMATION, PROPERTY OF SAN FRAN MFG. DO NOT REPRODUCE WITHOUT THE PRIOR WRITTEN CONSENT OF SAN FRAN MFG.

UNLESS OTHERWISE SPECIFIED DIMENSIONS ARE IN INCHES TOLERANCES ARE:
 DECIMALS ANGLES
 .X : +/- 0.050 X : +/- 1.0°
 .XX : +/- 0.020 X.X : +/- 0.5°
 .XXX : +/- 0.010 X.XX : +/- 0.05°
 ALL Ø's FOR PEM HARDWARE
 +.001 -.002

CAD GENERATED DRAWING: DO NOT MANUALLY UPDATE DO NOT SCALE DRAWING

SCALE: 1:8

APPROVALS DATE
 PART CMM 06/12/18
 DRAWING CMM 06/12/18
 CHECKED []

San Fran Mfg.
 4048 Technology Way, Ste. F
 Carson City, NV 89706
 800-957-9523 intl: 775-996-2280

PROJECT []
 DESCRIPTION SF6 Roaster - Korea
 SIZE DWG. NO. SF6-000
 REV. A
 SHEET 1 OF 1

