

REV.	ZONE	DESCRIPTION	DATE	APPROVED
A		INITIAL RELEASE	06/11/18	CMM

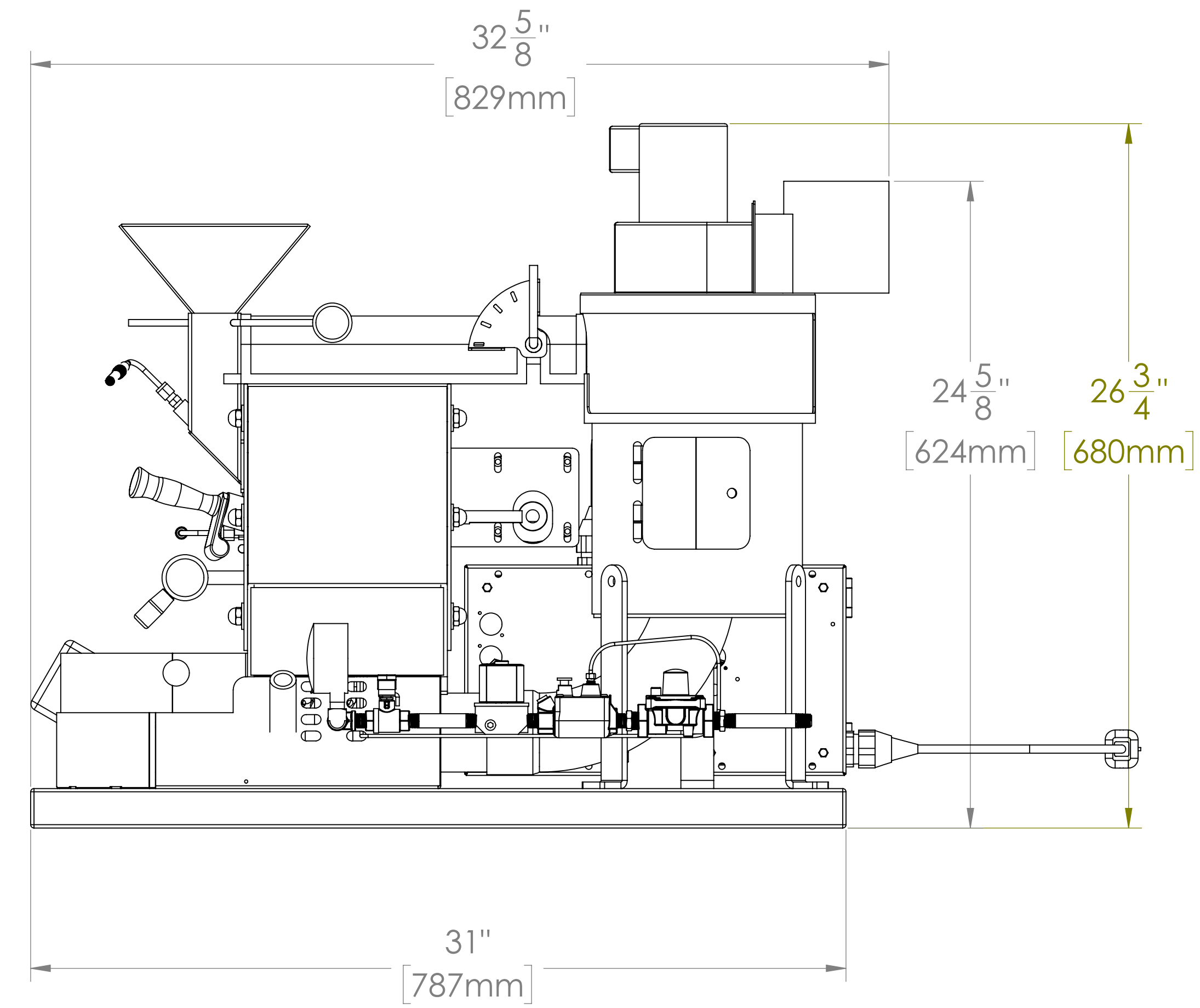
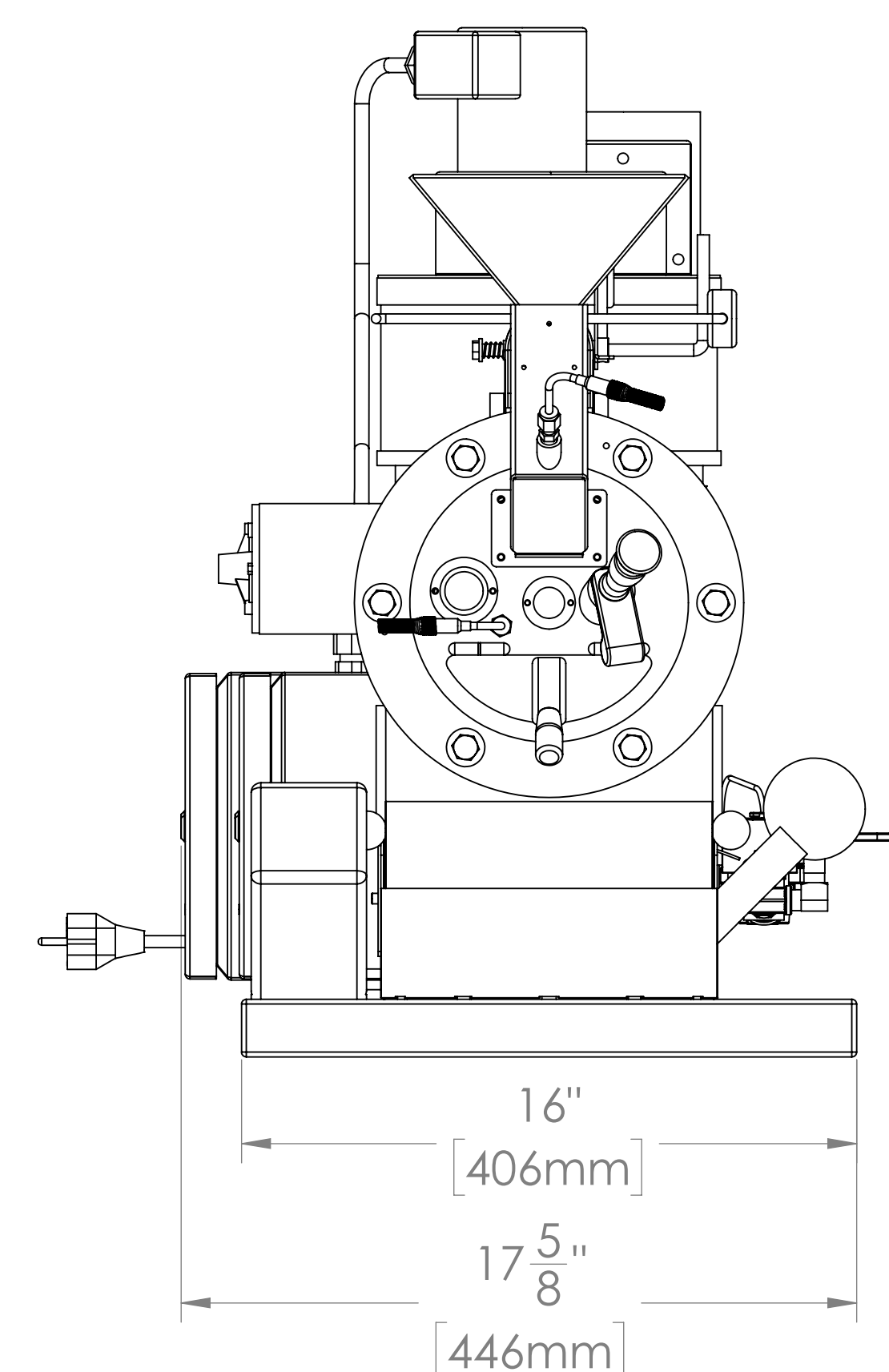
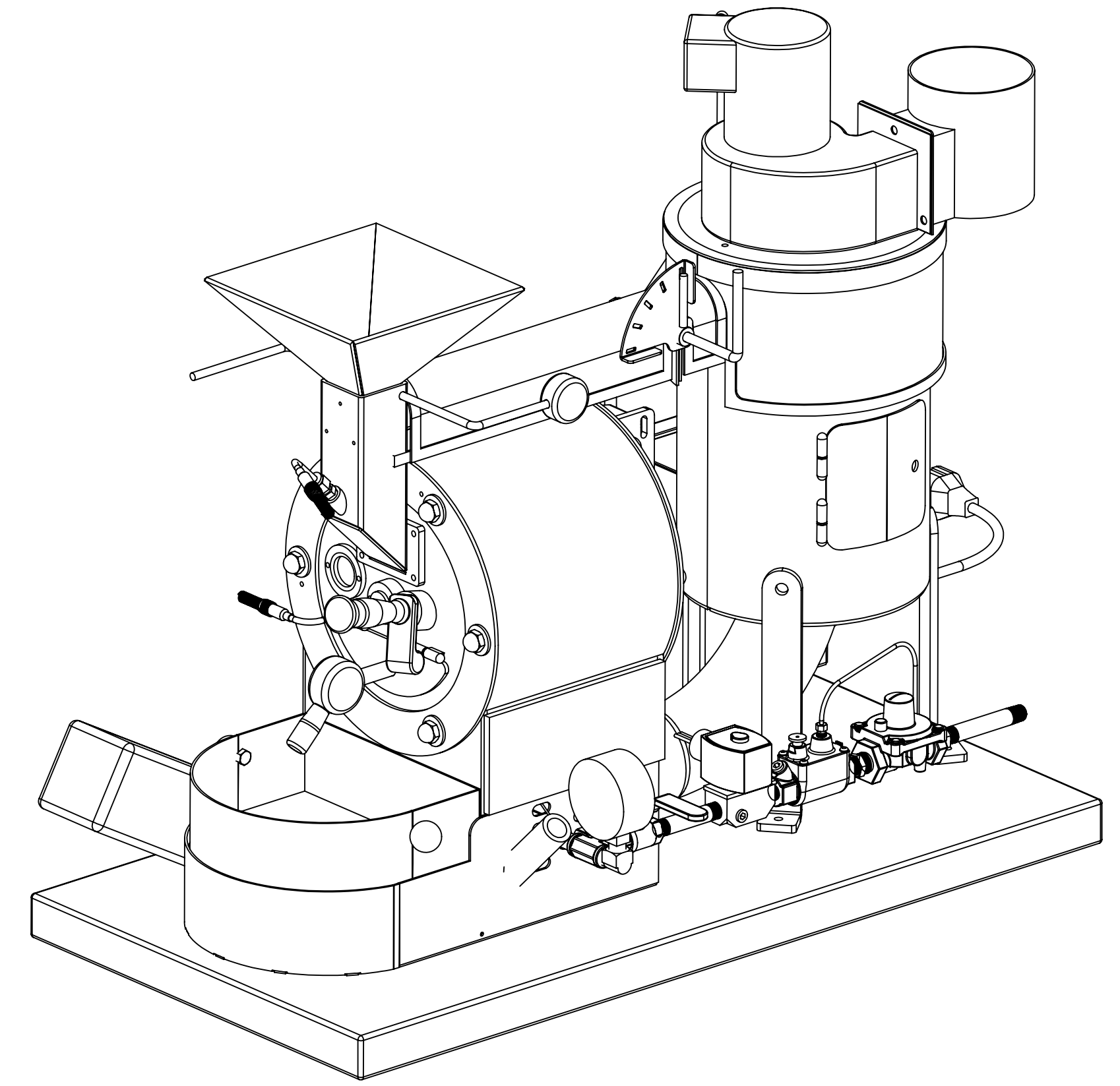
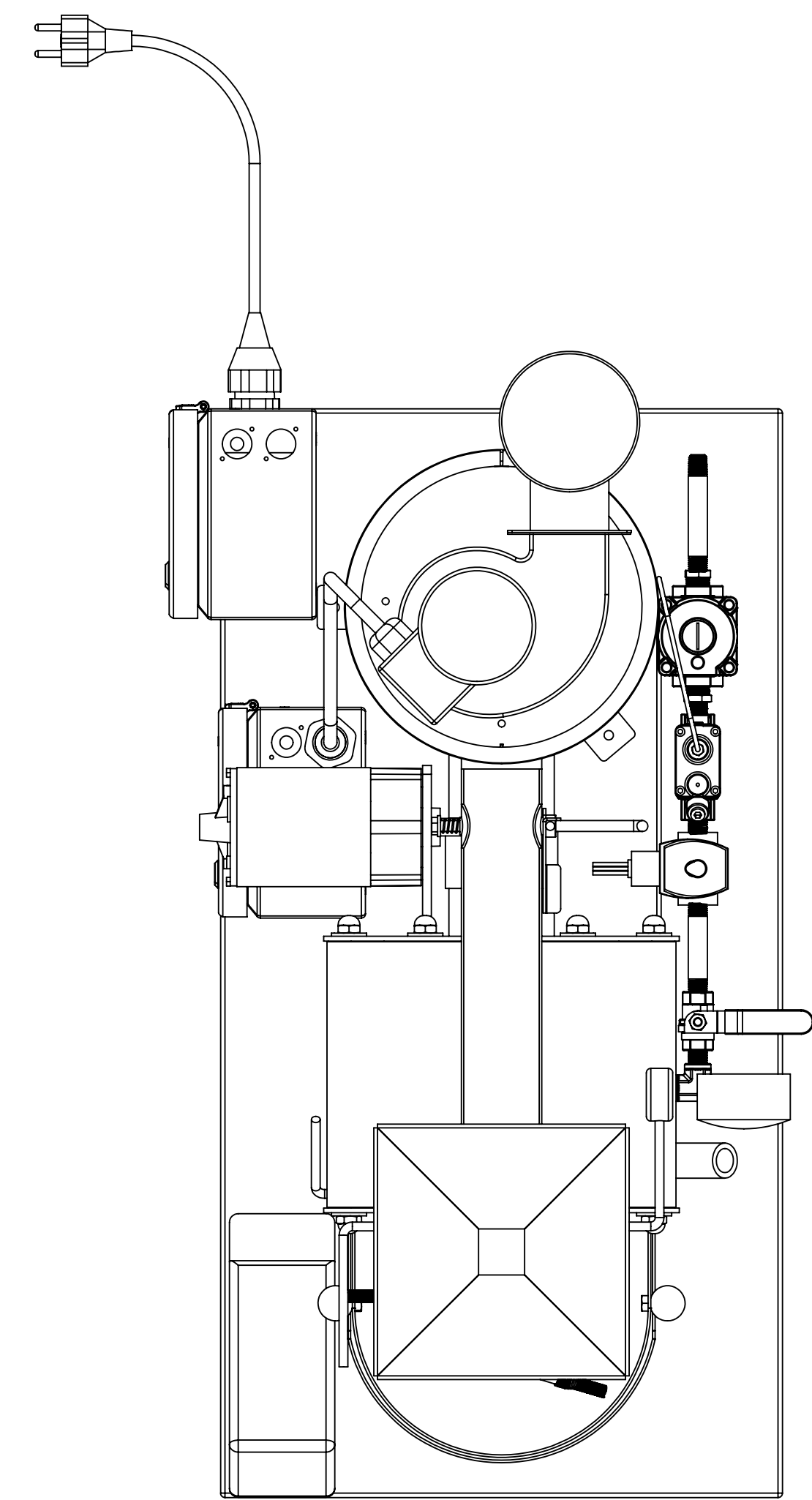

MAINTAIN 18" CLEARANCE FROM ALL COMBUSTIBLES AROUND ROASTER PERIMTER

Specifications	
Weight	137 lbs / 62.1 kg
Dimensions (L x W x H)	33" x 16" x 27" / 83.8 cm x 40.7 cm x 68.6 cm
Hot Air Exhaust	4" / 100 mm UL103 HT Positive Pressure Vent Pipe (130 CFM)
Voltage	220V, 60 HZ
Amperage	2A
Gas Line Req.	1/4" NPT
BTU	10,000 (7" WC Natural Gas / 11" WC Propane)
Approx. Hourly Rating	3 lbs / 1.4 kg green; 1.14 kg roasted
Certification	ETL Listed USA and Canada

<small>PROPRIETARY INFORMATION, PROPERTY OF SAN FRAN MFG. DO NOT REPRODUCE WITHOUT THE PRIOR WRITTEN CONSENT OF SAN FRAN MFG.</small>	<small>CAD GENERATED DRAWING: DO NOT MANUALLY UPDATE</small> DO NOT SCALE DRAWING		San Fran Mfg. 4048 Technology Way, Ste. F Carson City, NV 89706 800-957-9523 intl: 775-996-2280	
	<small>UNLESS OTHERWISE SPECIFIED DIMENSIONS ARE IN INCHES TOLERANCES ARE:</small> DECIMALS ANGLES .X : +/- 0.050 X : +/- 1.0° .XX : +/- 0.020 X.X : +/- 0.5° .XXX : +/- 0.010 X.XX : +/- 0.05° ALL Ø's FOR PEM HARDWARE +.001 -.002	SCALE: 1:4	PROJECT: []	DESCRIPTION: SF1 Roaster - Korea
APPROVALS: [] PART: CMM	DATE: 06/11/18	SIZE DWG. NO.: D	REV. A	SHEET 1 OF 1
DRAWING: CMM 06/11/18	CHECKED: []	CUSTOMER: []	DWG. NO.: SF1-001	SHEET 1 OF 1